

(SWIVEL NOZZLE CLAMPS) **ZPF**

SWIVEL NOZZLE CLAMPS

ZPF swivel clamps are specially designed for HGQ, RGN and ZBA series. To install them on pipes all you need is drill a hole, insert the nozzle clamp inside and fasten it with a simple screwdriver. The nozzle clamp body is in PP chemically bonded fibreglass whereas accessorial bolts and screws are made in stainless steel AISI 316. They are robust, easy to install, adjust and service and their design revolutioned modern surface pre-treatment plants. They provide excellent performance at high temperatures and easy spray jet orientation.

TYPICAL APPLICATION

Cleaning equipment used in pre-treatment for coating process

MAX WORKING TEMPERATURE

LT 90°C

MAX WORKING PRESSURE

LP 5 bar

MATERIAL Body
Pin & bolt
O-ring

D6 PP, chemically bonded fibreglass
B3 AISI 316 Stainless Steel
E8 NBR

CODE	PS inch	PD mm	D mm	H mm	H1 mm	L mm	A deg	W g
ZPF A125 D6	1 1/4"	41/43	20.0	83	54	84	40°	85
ZPF B125 D6			17.0					
ZPF C125 D6			14.0					
ZPF A150 D6	1 1/2"	46/49	20.0	90	57	90	40°	88
ZPF B150 D6			17.0					
ZPF C150 D6			14.0					

HOW TO MAKE UP THE PRODUCT CODE

Ex.: ZPF A125 D6

ZPF **A125** **D6**

MATERIAL • **D6** - PP, chemically bonded fibreglass

CODE

SWIVEL NOZZLE PIPE CLAMPS

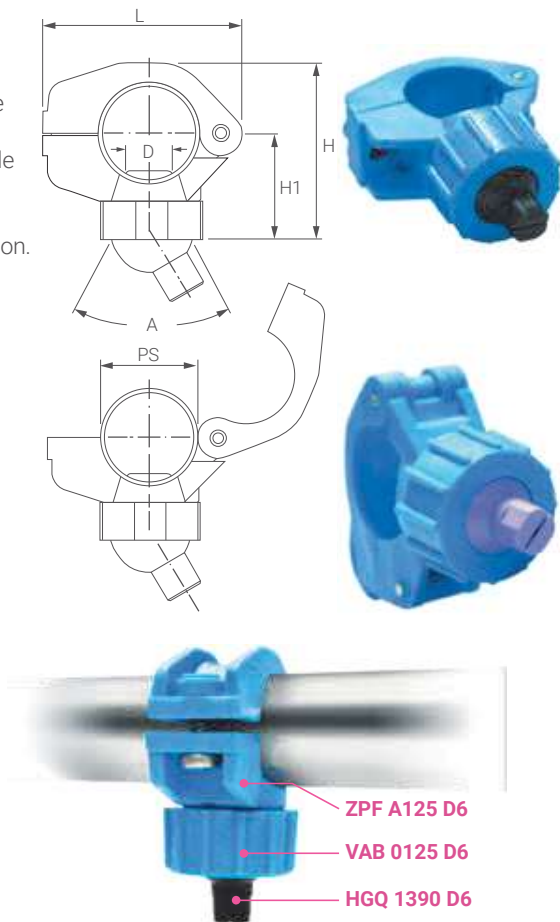

(SWIVEL NOZZLE CAM AND LEVER CLAMPS) **ZPQ**

SWIVEL NOZZLE CAM AND LEVER CLAMPS

ZPQ cam and lever clamps are specially designed for HGQ, RGN and ZBA ball nozzles. Only three steps to install them on a pipe: drill a hole, wrap the cam around the pipe and pull the lever down to block it. No need of tools. The body is in PP chemically bonded fibreglass whereas accessorial bolts and screws are made in stainless steel AISI 316. ZPQ swivel nozzles with cam and lever clamps provide excellent performance at high temperatures and easy spray jet orientation.

COMMON APPLICATION

Surface pre-treatment plants

MAX WORKING TEMPERATURE

LT 90°C

MAX WORKING PRESSURE

LP 5 bar

MATERIAL Body
Pin & bolt
O-ring
Seal

D6 PP, chemically bonded fibreglass
B3 AISI 316 Stainless Steel
E8 NBR
D22 Soft polypropylene

CODE	PS inch	PD mm	D mm	H mm	H1 mm	L mm	A deg	W g
ZPQ A125 D6	1 1/4"	42/43	20.0	93	41	84	40°	87
ZPQ B125 D6			17.0					
ZPQ A150 D6	1 1/2"	48/49	20.0	96	44	95	40°	97
ZPQ B150 D6			17.0					

HOW TO INSTALL THE SWIVEL NOZZLE CAM & LEVER CLAMPS

