

UPB (MIXING EDUCTORS)

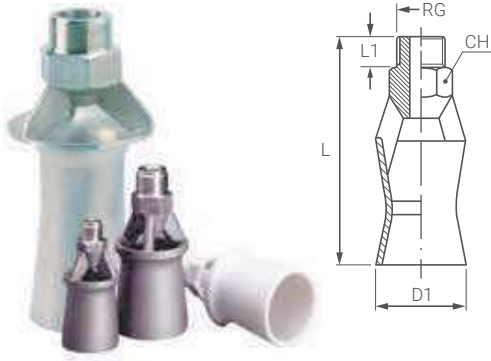

MIXING EDUCTORS

UPB mixing eductors are energy saving products. Their robust bell-shaped body minimizes the risk of damage during maintenance operations and the Venturi design assures a high mixing efficiency. These eductors enable the circulation of large volumes of liquid and are ideal for continuous blending and stirring of liquids or solutions in tanks. The UPB eductors are installed at the bottom of a tank and pressurized to spray the solution. This flow creates a powerful negative pressure that allows to take in four times the liquid volume, mix it with a solution inside the nozzle and spray it back into the tank at a high speed. 1 HP pump and UPB mixing eductor can replace a 5 HP mixing eductor. UPB eductors are an efficient way to get the best performance from re-circulating process tanks and are cost-effective because they reduce the electrical costs.

STEAM CONSUMPTION CHART

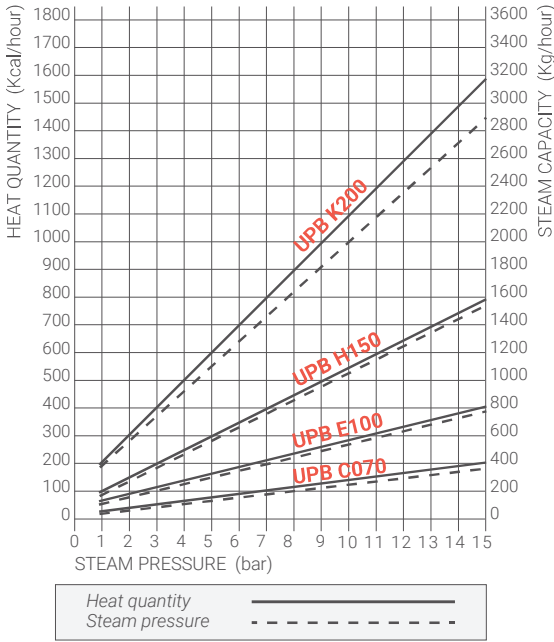

The table above shows the working condition of UPB C070 B31 eductor when set at 50 cm depth. We are at your disposal to realize UPB eductors on demand: PNR will give you the code and the dimensions.

TYPICAL APPLICATIONS Liquid mixing in electroplating and automotive paint factories
 THREAD SPEC. BSPT (B, solo AISI), BSPP (G, PP & PVDF), NPT (N, all)
 MAX WORKING TEMPERATURE LT 80 °C (PP), 90 °C (PVDF)
 MATERIAL B31 AISI 316L Stainless Steel
 D6 PP, chemically bonded fiberglass
 D82 PVDF, moulded

CODE	RG inch	D mm	Flow rate at pressure (l/min) (bar)					D1 mm	L mm	L1 mm	WS mm
			1.0	2.0	3.0	4.0	5.0				
UPB B030 D82Sx	1/4"	3.0	5.9	8.2	9.9	11	13	38	78	---	---
UPB B030 D6Sx		3.0	5.9	8.2	9.9	11	13				
UPB B040 D6Sx		4.0	10	15	18	20	23				
UPB B050 D6Sx		5.0	16	22	27	31	35				
UPB C070 B31Sx	3/8"	7.0	34	48	59	68	76	45	98	15	22
UPB C070 D6Sx		7.0	34	48	59	68	76				
UPB C070 D82Sx		7.0	34	48	59	68	76				
UPB E100 B31Rx	1/2"	10.0	63	89	109	126	141	60	132	20	30
UPB E100 B31Sx	3/4"	10.0	63	89	109	126	141	60	132	20	30
UPB E100 D6Sx			63	89	109	126	141				
UPB H150 B31Sx	1 1/2"	15.0	155	215	265	305	340	110	225	30	60
UPB K200 B31Sx	2"	20.0	268	377	460	531	592	102	295	30	70

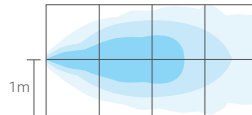

Under normal operating conditions, with feed pressure values ranging from 2 to 4 bars, eductors with a total capacity equal to 20% of the liquid volume to be stirred proved to be adequate for most industrial applications.

UPD (MIXING EDUCTORS)

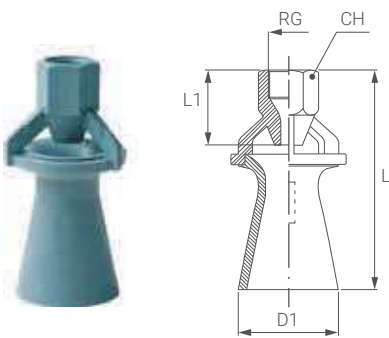

MIXING EDUCTORS

UPD mixing eductors, whose design applies the "Coanda Effect", enable the circulation of large volumes of liquid. They are installed at the bottom of a tank and pressurized to spray the solution. This flow creates a powerful negative pressure that allows to take in four times the liquid volume, mix it with a solution inside the nozzle and spray it back into the tank at a high speed. 1 HP pump and UPD mixing eductor can replace a 5 HP mixing eductor. UPD eductors offer a high mixing efficiency and are cost effective because they save energy and are resistant to wear and corrosion. UPD eductors have the same technical features of the UPB models, but they come with a female thread connection.

THREAD SPECIFICATION BSP (G), NPT (N)
 MATERIAL B31 AISI 316L Stainless Steel
 D6 PP, PP, chemically bonded fiberglass
 MAX WORKING TEMPERATURE LT 80 °C (PP)
 TYPICAL APPLICATIONS Liquids mixing in electroplating, automotive painting, chemical plants.

CODE	RG inch	D mm	Flow rate at pressure (l/min) (bar)					D1 mm	L mm	L1 mm	WS mm
			1.0	2.0	3.0	4.0	5.0				
UPD E100 D6Sx	3/4"	10	63	89	109	126	141	75	147	30	34
UPD H150 D6Sx	1 1/2"	15	140	198	243	281	314	80	225	45	60
UPD H150 B31Sx	1 1/2"	15	155	215	265	305	340	80	239	83	60
UPD K200 B31Sx	2"	20	268	377	460	531	592	102	295	83	70