

## STANDARD AND LARGE CAPACITIES

GY flat fan nozzle tips are usually mounted onto a pipe by means of a welding nipple and secured in place with a retaining nut. Therefore, they can be easily replaced and their dovetail connection assures an always precise assembly as the nozzle can be assembled only when the flat fan is properly oriented. They are available in three types: 3/8" standard capacity, 3/4" large capacity and 1" extra-large capacity. The tip models shown on this page deliver the most popular capacity values, while GY flat fan tips with bigger capacities and sizes can be manufactured on request and supplied with matching dovetail nipples and retaining nuts. Please find information about instalment and accessories on page 89.

- **Connection:** Dovetail flat fan tips
- **Typical applications**
  - **Washing:** steel cleaning  
filter cloth cleaning  
parts cleaning
  - **Cooling:** steel cooling, product cooling

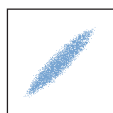

Spray section

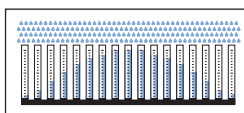

Convex distribution



## SPRAY ANGLE CODES

GYA	GYF	GYM	GYQ	GYU	GYW
0°	30°	45°	60°	90°	120°

## ASSEMBLY FITTINGS

The picture below shows a GY nozzle tip (in the middle) assembled with a dovetail nipple (right) and a locknut (left).

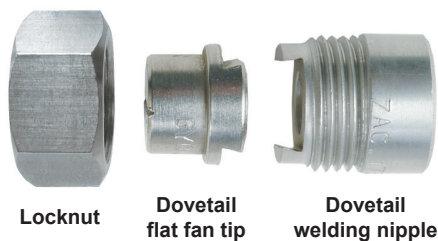

## DOVETAIL NIPPLES

GY nozzle tips are assembled onto their own series of matching dovetail nipples, to assure perfect alignment: the two tip sizes require nipples and caps as shown in the table below.

The orientation of the spray jets, properly inclined to avoid their interfering, is automatically obtained welding the nipples in place with their dovetail aligned along the pipe axis. This is easily done by running a straight rule across the dovetail profile machined on the nipple.

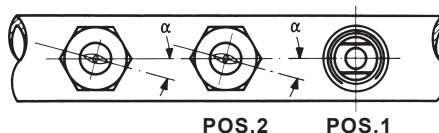
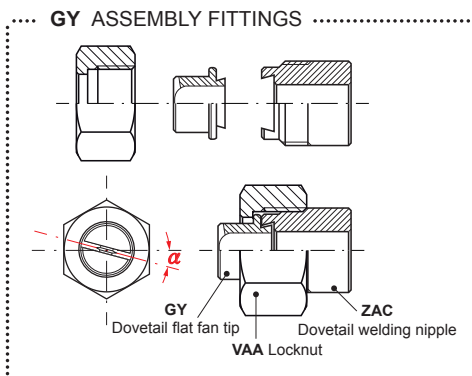

See values for jet deviation angle ( $\alpha$ ) beside capacity tables next page.

### HOW TO MAKE UP THE NOZZLE CODE

EX.: GYF 1190 B1

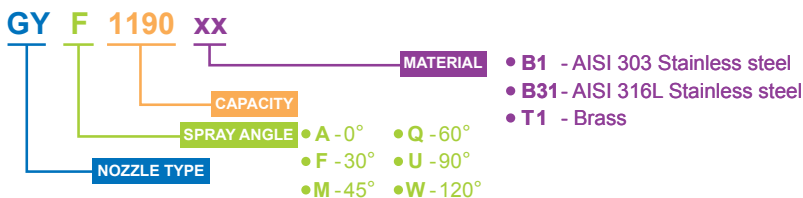

STANDARD AND LARGE CAPACITIES

3/8" STANDARD CAPACITY TIPS

Jet deviation angle  $\alpha = 5^\circ$



GYF 30°	GYM 45°	GYQ 60°	GYU 90°	GYW 120°	Capacity code	D mm	Capacity at different pressure values (l/min) (bar)									
							0.5	1.0	1.5	2.0	3.0	4.0	5.0	7.0	10	
•	•	•	•	•	1190	1.30	0.78	1.10	1.34	1.55	1.90	2.19	2.45	2.90	3.47	
•	•	•	•	•	1233	1.50	0.95	1.35	1.65	1.90	2.33	2.69	3.01	3.56	4.25	
•	•	•	•	•	1310	1.70	1.27	1.79	2.19	2.53	3.10	3.58	4.00	4.74	5.66	
•	•	•	•	•	1385	1.80	1.57	2.22	2.72	3.14	3.85	4.45	4.97	5.88	7.03	
•	•	•	•	•	1490	2.10	2.00	2.83	3.46	4.00	4.90	5.66	6.33	7.48	8.95	
•	•	•	•	•	1581	2.30	2.37	3.35	4.11	4.74	5.81	6.71	7.50	8.87	10.6	
•	•	•	•	•	1780	2.70	3.18	4.50	5.52	6.37	7.80	9.01	10.1	11.9	14.2	
•	•	•	•	•	1980	3.00	4.00	5.66	6.93	8.00	9.80	11.3	12.7	15.0	17.9	
•	•	•	•	•	2124	3.40	5.06	7.16	8.77	10.1	12.4	14.3	16.0	18.9	22.6	
•	•	•	•	•	2153	3.80	6.25	8.83	10.8	12.5	15.3	17.7	19.8	23.4	27.9	
•	•	•	•	•	2194	4.30	7.96	11.3	13.8	15.9	19.5	22.5	25.2	29.8	35.6	

3/4" LARGE CAPACITY TIPS

Jet deviation angle  $\alpha = 15^\circ$

GYA 0°	GYF 30°	GYM 45°	GYQ 60°	GYU 90°	GYW 120°	Capacity code	D mm	Capacity at different pressure values (l/min) (bar)									
								0.5	1.0	1.5	2.0	3.0	4.0	5.0	7.0	10	
•	•	•	•	•	•	1781	2.70	3.18	4.50	5.52	6.37	7.80	9.01	10.1	11.9	14.2	
•	•	•	•	•	•	1981	3.00	4.00	5.66	6.93	8.00	9.80	11.3	12.7	15.0	17.9	
•	•	•	•	•	•	2125	3.40	5.06	7.16	8.77	10.1	12.4	14.3	16.0	18.9	22.6	
•	•	•	•	•	•	2154	3.80	6.25	8.83	10.8	12.5	15.3	17.7	19.8	23.4	27.9	
•	•	•	•	•	•	2195	4.30	7.92	11.2	13.7	15.8	19.4	22.4	25.0	29.6	35.4	
•	•	•	•	•	•	2246	4.80	10.0	14.2	17.4	20.1	24.6	28.4	31.8	37.6	44.9	
•	•	•	•	•	•	2311	5.40	12.7	18.0	22.0	25.4	31.1	35.9	40.1	47.5	56.8	
•	•	•	•	•	•	2490	6.40	20.0	28.3	34.6	40.0	49.0	56.6	63.3	74.8	89.5	
•	•	•	•	•	•	2610	7.50	24.9	35.2	43.1	49.8	61.0	70.4	78.8	93.2	111	
•	•	•	•	•	•	2760	8.30	31.0	43.9	53.7	62.1	76.0	87.8	98.1	116	139	
•	•	•	•	•	•	3122	12.5	49.8	70.4	86.3	99.6	122	141	158	186	223	

ASSEMBLY FITTINGS CODING

Name	Code and material	Appearance	Model no.	
			Standard size 3/8"	Large size 3/4"
Locknut <i>P.88</i>	B1 - AISI 303 SS B3 - AISI 316 SS T1 - Brass		VAA 0381 xx	VAA 0750 xx
Dovetail welding nipple <i>P.89</i>	B1 - AISI 303 SS B31 - AISI 316L SS		ZAC 1738 xx	ZAC 2775 xx

HOW TO MAKE UP THE NOZZLE CODE

EX.: GYF 1190 B1

